



INTRODUCTION

Thank you for purchasing Sonance Symphony® in-wall speakers. When properly installed, these speakers will give you many years of entertainment pleasure. To get the most out of your new speakers, please read this manual thoroughly before you begin installation.

Since all of the Sonance Symphony in-wall speakers have the same exact footprint and have identical installation requirements, the directions in this manual apply to all of the following models:

- Symphony S625_T
- Symphony S622_T
- Symphony S624_T
- Symphony S621_T
- Symphony S623_T

To achieve the best performance, Sonance recommends that these speakers be installed by a Sonance Authorized Dealer/Installer.

PARTS LIST

Your Sonance Symphony in-wall speakers include the following:

- (2) Sonance Symphony Speakers
- (2) Paintable Grilles
- (2) Plastic paint plugs to protect the speakers during painting
- (1) Mounting cutout template (in packaging)

OPTIONAL ACCESSORIES

Symphony FlexBracket (part# 92091) and **Symphony Staple Template** (part# 900651) — Plastic templates to reserve a mounting hole for the speaker in new construction. Designed to be used with the RotoLock® mounting system.

Symphony Coverplate (part# 92093) — Covers the hole made by the FlexBracket during construction until the speaker is installed.

Symphony Retrofit Enclosure (part# 92099) — Molded enclosure that reduces sound transmission into adjacent rooms and spaces. Can be used in installations where the speaker is retrofitted into existing walls.

Sonafill® In-Wall System (part# 91698) — Retrofittable acoustical treatment for in-wall speakers consisting of two pillows and four tiles that virtually eliminates noises produced by resonating drywall. Dramatically improves midbass sound quality and reduces sound transmission into adjacent rooms.

Symphony Acoustic Enclosure (part# 91687) — ½" MDF enclosure that provides ideal acoustic performance and maximum reduction of sound transmission into adjacent spaces. Designed for use only in new construction.

Fire-Rated Back Can (part# 91907) — Meets ASTM E 119, CAN/ULC S 101, NFPA 251, UBC 7-1 and UL 263 criteria for commercial installations.

SPEAKER PLACEMENT

Note: All Sonance Symphony in-wall speakers fit into walls built with standard 2" x 4" stud construction. The locations of the speakers should be determined by considering your primary listening location, the primary use for the speakers (stereo music or home theater) and aesthetic values. For optimum results contact your Authorized Sonance Dealer for advice.

Home Theater Placement

Left and Right Channels

- Place the speakers on either side of the video screen, anywhere from 6 feet to 10 feet apart and 38 – 42 inches from the floor (which corresponds to

INSTRUCTION MANUAL

SONANCE SYMPHONY® SERIES 6.5" IN-WALL SPEAKER

the height of your ears when you're seated on a couch or chair).

- If possible, locate the speakers at least 18 inches away from the side walls.
- The main listening position should be between 8 and 12 feet away from the speakers.

Use Illustration 1 as a guide.

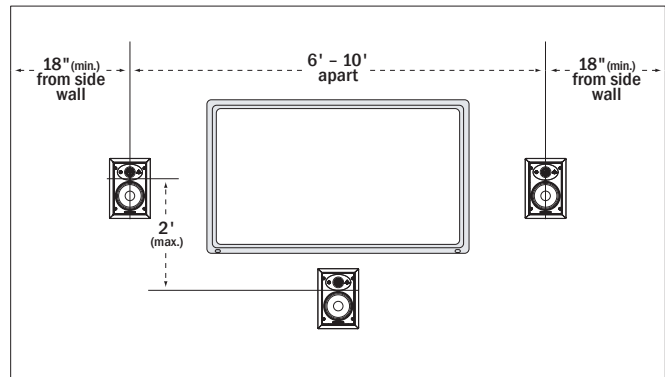

Illustration 1: Home Theater Placement — LCR Speakers

Center Channel

- If possible, locate the center speaker at the same height as the left & right speakers (38 – 40 inches from the floor).
- If you must place the center speaker above or below a video screen, we recommend placing it no more than 2 feet above or below the center of the left and right speakers. Keeping the speakers within this 4-foot window will maintain consistent tonality between all 3 speakers.

Use Illustration 1 as a guide.

Surround Channel

Sonance Symphony speakers can be used for surround channel as well as front channel applications in a home theater. Depending on your room's layout, you can locate the surround channel speakers in the side walls, in the rear wall or in the ceiling. If you are not sure which location for the surround channel speakers will achieve the best performance in your room, contact your Authorized Sonance Dealer for advice.

- *Side-wall mounting:* Locate the surround channel speakers approximately 2 feet to 6 feet behind the listening position, at least 5 feet from the floor.

Use Illustration 2 as a guide.

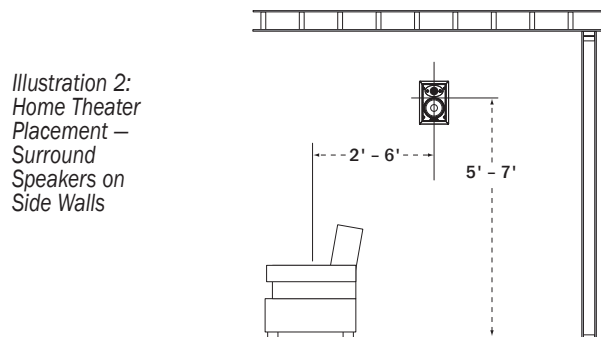

Illustration 2:
Home Theater
Placement —
Surround
Speakers on
Side Walls

- *Rear-wall mounting:* The rear wall should be between 2 feet and 10 feet behind the listening position. Locate the surround channel speakers between 6 feet and 10 feet apart, at least 5 feet from the floor.

If possible, separate the surround channel speakers the same distance as the front left and right speakers. This placement is gaining popularity with people who use their surround systems for multi-channel music listening as well as watching films.

Use Illustration 3 as a guide.

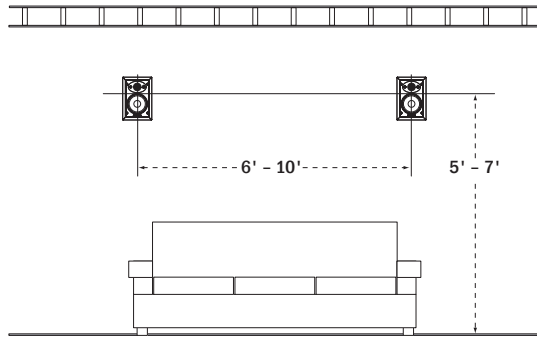

Illustration 3:
Home Theater Placement – Surround Speakers on Rear Wall

- **Ceiling mounting:** Locate the speakers on the ceiling between 2 feet and 6 feet behind the listening position. The speakers should be between 6 feet and 10 feet apart.

2-Channel Placement

Follow the directions for left & right channel Home Theater Placement. However, if the listeners will be standing instead of seated, locating the speakers approximately 5' (60") from the floor will keep them around ear level.

WIRE GAUGE

Extra resistance in the speaker wire can make a speaker sound less dynamic and reduce definition of the bass frequencies. In extreme cases, it can even attenuate high frequencies. Also, amplifier power is wasted in wire with extra resistance, reducing your system's maximum output level.

To prevent degrading sound quality, the total wire resistance should be less than 10% of the speaker's impedance. This means that for an 8-ohm speaker, the total resistance of the wire should be less than 0.8 ohms.

Refer to the following table when selecting the proper wire gauge for your system:

Wire resistance in Ohms vs. length of cable run						
Distance in Feet	50'	100'	150'	200'	250'	300'
20 gauge	1.04	2.07	3.11	4.14	5.18	6.22
18 gauge	.65	1.30	1.96	2.61	3.26	3.91
16 gauge	.41	.82	1.22	1.63	2.04	2.45
14 gauge	.26	.52	.77	1.03	1.29	1.55
12 gauge	.16	.32	.49	.65	.81	.97
10 gauge	.10	.20	.31	.41	.51	.61

PREPARING THE INSTALLATION LOCATION

All Sonance speakers are designed to be relatively insensitive to variations in enclosure volume. To achieve the ultimate performance from your speakers, a section of the stud bay can be sectioned-off to form a back box. Building such an enclosure will create a dramatic improvement in bass performance and power handling.

Ideal back box volume requirements:

Symphony S625 _T	1.5 ft ³
Symphony S624 _T	1.5 ft ³
Symphony S623 _T	1.5 ft ³
Symphony S622 _T	1.2 ft ³
Symphony S621 _T	1.0 ft ³

Symphony Retrofit Enclosures

For installations where it isn't possible to section-off the wall's stud bay to form a back box or install the Symphony Acoustic Enclosure (such as when you're retrofitting the speakers into existing walls), you can effectively reduce sound transmission into adjacent rooms by fitting the speakers with optional Symphony Retrofit Enclosures (part# 92099). This backbox is designed specifically to be used with Symphony speakers, and will noticeably reduce sound "spillover" from the rear of the speakers into adjacent rooms and spaces.

Insulating the Wall Cavity

To reduce sound transmission to adjacent rooms and further improve speaker performance, insulate the wall cavity by inserting a sheet of unfaced fiberglass insulation above and below the speaker.

To reduce noise produced by unsupported drywall, install fiberglass insulation in the bays adjacent to the speaker location.

INSTALLING THE SPEAKERS

New Construction

For installations in new construction, Sonance recommends using a Symphony FlexBracket (part#92091) to reserve a location for the speaker. The FlexBracket is nailed or screwed to the studs and serves as a guide for the drywaller so that the speaker hole will be in the desired location once the drywall is installed.

Symphony FlexBrackets are compatible with the RotoLock mounting system (see *Retrofit*, below).

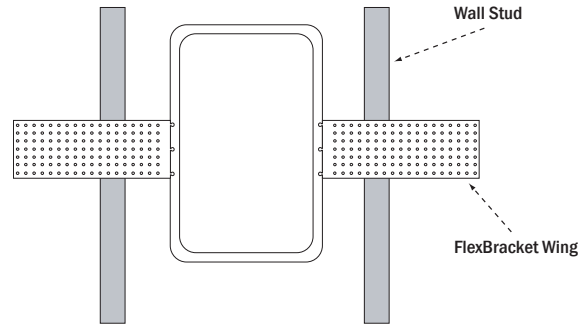

Illustration 4: Symphony FlexBracket Installation

Retrofit

Symphony Speakers feature an integral RotoLock® mounting system for quick mounting directly into existing walls. Once the hole is cut and the cable is run, you can install the speaker in a matter of seconds.

1. Determine the location for the speaker (see *Speaker Placement*).
2. Perform an obstruction survey to be certain that there are no studs, conduit, pipes, heating ducts or air returns that will interfere with the speaker.
3. The cutout for all Symphony Speakers is 7¹/₁₆" (179mm) x 11¹/₄" (286mm). There also must be at least 3⁷/₈" (99mm) depth within the wall cavity for the speaker.
4. Find the cutout template provided in the speaker packaging. Position the template where the speaker is to be located and pencil an outline on the wall.
 - If you are unsure about obstructions, drill a small hole in the center of the outline and insert a coat hanger wire into the hole to feel-around for possible obstructions.
5. Cut the hole using a drywall saw, and run the speaker wires.
6. Remove the paint plug from the speaker. Connect the speaker wire to the terminals on the back of the speaker. Double-check that you connected amplifier + to speaker + and amplifier - to speaker -.

7. Insert the speaker into the hole in the wall.

Note: The RotoLock system can accommodate a maximum wall material thickness of 1³/₈".

Step 7:

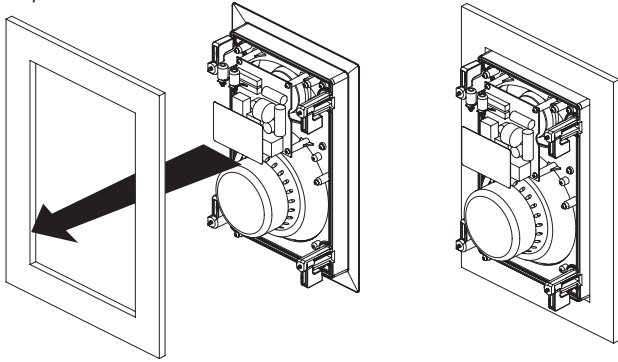

8. Tighten the four screws on the front of the speaker baffle. The RotoLock clamps will automatically rotate into position and begin clamping the speaker.

- When you notice resistance on the four screws the speaker has been clamped successfully.

The speaker flange is designed to flex and conform to any small imperfections in the wall surface. Do not tighten the screws so much so that the flange bows-out.

Important: Always use low-torque settings – NEVER over-tighten.

Step 8:

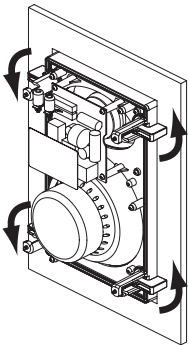

Step 9:

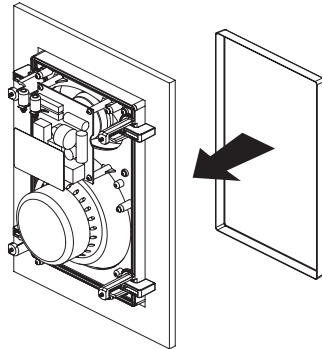

9. Attach the grille after the speaker has been installed. Insert about half of the grille into the groove at the edge of the speaker. Gently fit the remaining half of the grille by working around the speaker, fitting the grille into the groove as you go.

Note: You can adjust the torque applied to the RotoLock screws to achieve a proper grille fit.

IR Receiver Knockout

All Symphony speakers have a knockout for installing an IR receiver into the speaker's front baffle. This allows you to aim remote controls at the front of the room instead of at the electronics, in systems where the electronics may be placed in an inconvenient location.

To remove the knockout, drill it out from the rear using a drill with a 1/2" bit (there is a sleeve guide directly behind the knockout).

After inserting the IR receiver through the hole, seal it into the speaker using silicone caulk (make sure that there are no gaps around the receiver that could create air leaks) and

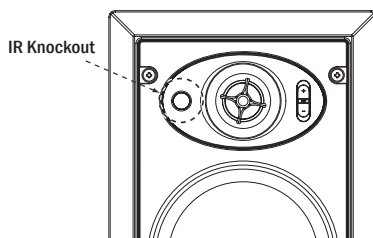

Illustration 5: IR Knockout

dress the wire into the groove on the back of the baffle.

Note: The speaker's grille may reduce the effectiveness of the IR receiver. If this occurs, slightly enlarge the holes in the grille that are directly in front of the IR receiver.

PAINTING THE SPEAKERS AND GRILLES

You can paint the speakers and grilles before installing them, which will eliminate the "paint scar" if the speaker ever needs to be removed for service. You can also paint the speakers after installation, but before the grilles are attached. All Symphony speakers come from the factory fitted with a plastic 'paint plug'. Use the paint plug to protect the speaker drivers while the flange is being painted along with the wall.

Sonance always suggests painting the grille separately from the speaker. Before painting, carefully remove the under-grille cloth. It is held in place with a light tacking glue that makes it easy to remove.

Spray the grilles with thinned paint (5 parts thinner to 1 part paint), being careful not to plug the holes. Too heavy a coat of paint on the grille will adversely affect the sound of the speaker.

Once the grilles and flange are painted and dry, replace the under-grille cloth, remove the paint plug from the speaker flange and install the grille.

ADJUSTING YOUR SPEAKERS

Pivoting Tweeter

All Symphony Speakers (except the S621T) have a pivoting tweeter that can direct sound toward or away from the listening area.

If you're using the speakers in stereo or as the front L/C/R speakers in a home theater, pivot the tweeter directly towards the listening area. This can be especially helpful if the speakers are widely-separated and the music fails to blend into a central sonic image.

If you're using the speakers as surround channel speakers in a home theater, you can create a more diffuse, spacious surround effect by aiming the tweeters towards a wall or window, away from listeners.

To pivot the tweeter:

Apply light pressure on the plastic ring around the outside edge of the tweeter dome. **Note: Do not touch or apply pressure to the tweeter dome.**

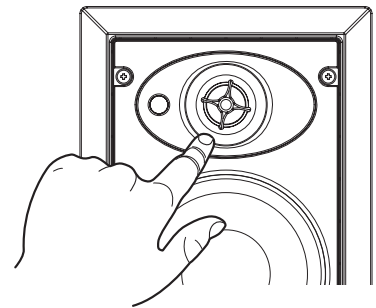

Illustration 6: Pivoting the Tweeter

Tweeter Level Control

The Symphony S623T, S624T and S625T have a tweeter level control switch that lets you boost or cut the tweeter's level by 3dB.

Once you have installed the speakers, listen to a variety of music that you are familiar with. If the music all tends to sound too bright, adjust the level control to the "-" (-3dB) position. If the music all tends to sound too dull, adjust the level control to the "+" (+3dB) position. If some recordings sound dull and some sound bright, the speaker is accurately reproducing differences in the recordings, and you should leave the control in the middle (0dB) position.

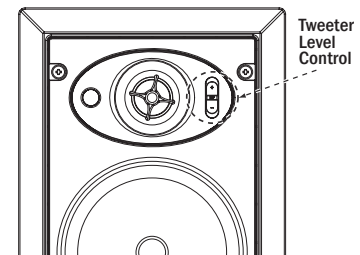

Illustration 7: Tweeter Level Control



SPECIFICATIONS

S625T

Tweeter	1" (25mm) Beryllium Dome, Ferrofluid cooled, pivoting
Woofers	6½" (165mm) Beryllium cone, rubber surround, extended pole piece
Frequency Response	40Hz – 20kHz ±3dB
Impedance	6 Ohms nominal; 4 Ohms minimum
Power Handling	5 watts minimum; 150 Watts maximum
Sensitivity	90dB SPL (2.83V 1 meter)
Grille Material	Perforated Aluminum
Adjustments	±3dB tweeter level
Dimensions (W x H x D)	8¼" x 12¾" x 3¾" (210mm x 310mm x 86mm)
Cutout Dim. (W x H)	6¾" x 10¾" (172mm x 270mm)
Shipping Weight	12 lbs. (5.45 KG) Pair

S624T

Tweeter	1" (25mm) Aluminum Dome, Ferrofluid cooled, pivoting
Woofers	6½" (165mm) Coated carbon fiber cone, rubber surround, extended pole piece
Frequency Response	43Hz – 20kHz ± 3dB
Impedance	6 Ohms nominal; 4 Ohms minimum
Power Handling	5 watts minimum; 140 Watts maximum
Sensitivity	90dB SPL (2.83V 1 meter)
Grille Material	Perforated Aluminum
Adjustments	±3dB tweeter level
Dimensions (W x H x D)	8¼" x 12¾" x 3¾" (210mm x 310mm x 86mm)
Cutout Dim. (W x H)	6¾" x 10¾" (172mm x 270mm)
Shipping Weight	11 lbs. (5.0 KG) Pair

S623T

Tweeter	1" (25mm) Silk Dome, Ferrofluid cooled, pivoting
Woofers	6½" (165mm) Carbon Fiber cone, rubber surround
Frequency Response	43Hz – 20kHz ±3dB
Impedance	8 Ohms nominal; 6 Ohms minimum
Power Handling	5 watts minimum; 135 Watts maximum
Sensitivity	90dB SPL (2.83V 1 meter)
Grille Material	Perforated Aluminum
Adjustments	±3dB tweeter level
Dimensions (W x H x D)	8¼" x 12¾" x 3¾" (210mm x 310mm x 86mm)
Cutout Dim. (W x H)	6¾" x 10¾" (172mm x 270mm)
Shipping Weight	10 lbs. (4.5 KG) Pair

S622T

Tweeter	1" (25mm) Silk Dome, Ferrofluid-cooled, pivoting
Woofers	6½" (165mm) Polypropylene cone, rubber surround
Frequency Response	45Hz – 20kHz ±3dB
Impedance	8 Ohms nominal; 6 Ohms minimum
Power Handling	5 watts minimum; 125 Watts maximum
Sensitivity	89dB SPL (2.83V 1 meter)
Grille Material	Perforated Aluminum
Adjustments	None
Dimensions (W x H x D)	8¼" x 12¾" x 3¾" (210mm x 310mm x 86mm)
Cutout Dim. (W x H)	6¾" x 10¾" (172mm x 270mm)
Shipping Weight	10 lbs. (4.5 KG) Pair

S621T

Tweeter	¾" (19mm) Silk Dome, Ferrofluid-cooled
Woofers	6½" (165mm) Polypropylene cone, rubber surround
Frequency Response	50Hz – 20kHz ±3dB
Impedance	8 Ohms nominal; 6 Ohms minimum
Power Handling	5 watts minimum; 100 Watts maximum
Sensitivity	88dB SPL (2.83V 1 meter)
Grille Material	Perforated Aluminum
Adjustments	None
Dimensions (W x H x D)	8¼" x 12¾" x 3¾" (210mm x 310mm x 86mm)
Cutout Dim. (W x H)	6¾" x 10¾" (172mm x 270mm)
Shipping Weight	9 lbs. (4.1 KG) Pair

TECHNICAL ASSISTANCE AND SERVICE

If you any have questions about the operation or installation of this product, please call our Technical Assistance Department on any business day at (800) 582-0772 or (949) 492-7777; from 7 a.m. to 5 p.m., PST.

If your speakers should need repair or service, contact your Sonance Authorized Dealer for help, or use the following procedure:

1. Prior to calling, note the product's model number, serial number, purchase date, and the name and address of the dealer where you purchased the product.
2. Contact our Technical Assistance Department at the above number(s) and describe the problem the unit is experiencing. If applicable, they will issue a Return Authorization Number.

IMPORTANT: YOU MUST HAVE PRIOR AUTHORIZATION TO RETURN YOUR SPEAKER TO SONANCE!

3. If you're directed to return the unit to Sonance for repair, pack the unit in its original shipping carton. If needed, you can obtain replacement packaging from us for a small charge. Note: it is best if you place the box into an additional outer "overcarton" before shipment to minimize a chance of theft in shipment. Please include a copy of the original bill of sale inside the package.

4. Contact United Parcel Service, Federal Express, or RPS to arrange prepaid (not collect) shipping. Do not use the U.S. Mail Service.

IMPORTANT: FREIGHT COLLECT SHIPMENTS WILL BE REFUSED.

5. Write the Return Authorization Number on the outside of the shipping carton.

6. Ship the packaged unit to:

Quality Assurance Department
Sonance
212 Avenida Fabricante
San Clemente, CA 92672-7531

LIMITED LIFETIME WARRANTY COVERAGE (U.S. ONLY)

Sonance warrants to the original retail purchaser only that this Sonance product will be free from defects in materials and workmanship, provided the speaker was purchased from a Sonance Authorized Dealer.

Defective products must be shipped, together with proof of purchase, prepaid insured to the Authorized Sonance Dealer from whom they were purchased, or to the Sonance factor at the address listed on this instruction manual. Freight collect shipments will be refused. It is preferable to ship this product in the original shipping container to lessen the chance of transit damage. In any case, the risk or loss or damage in transit is to be borne by the purchaser. If, upon examination at the Factor or Authorized Sonance Dealer, it is determined that the unit was defective in materials or workmanship at any time during this warranty period, sonance or the Authorized Sonance Dealer will, at its option, repair or replace this product at no additional charge, except as set forth below. It this model is no longer available and can not be repaired effectively, Sonance, at its sole option, may replace the unit with a current model of equal or greater value. In some cases where a new model is substituted, a modification to the mounting surface may be required. If mounting surface modification is required, Sonance assumes no responsibility or liability for such modification. All replaced parts and product become the property of Sonance. Products replaced or repaired under this warranty will be returned to the original retail purchaser, within a reasonable time, freight prepaid.

This Warranty does not include service or parts to repair damage caused by accident, disaster, misuse, abuse, negligence, inadequate packing or shipping procedures, commercial use, voltage inputs in excess of the rated maximum of the unit, or service, repair or modification of the product which has not been authorized or approved by Sonance. This Warranty also excludes normal cosmetic deterioration caused by environmental conditions. This Warranty will be void if the Serial Number on the product has been removed, tampered-with or defaced. This Warranty is in lieu of all other expressed warranties. If the product is defective in materials or workmanship as warranted above, the purchaser's sole remedy shall be repair or replacement as provided above. In no event will Sonance be liable for any incidental or consequential damages arising out of the use or inability to use the product, even if Sonance or a Authorized Sonance Dealer has been advised of the possibility of such damages, or for any claim by any other party.

Some states do not allow the exclusion or limitation of consequential damages, so the above limitation and exclusion may not apply. All implied warranties on the product are limited to the duration of this expressed Warranty. Some states do not allow limitation on the length of an implied warranty. If the original retail purchaser resides in such a state, this limitation does not apply.

EXCLUSIONS AND LIMITATIONS

The warranty set forth above is in lieu of all other warranties, express or implied, of merchantability, fitness for a particular purpose, or otherwise. The warranty is limited to Sonance products registered herein and specifically excludes any damage to loudspeakers and other allied or associated equipment which may result for any reason from use with this product. Sonance shall, in no event, be liable for incidental or consequential damages arising from any breach of this warranty or otherwise. This warranty gives you specific legal rights, and you may have other rights which vary from state to state.

©2004 Sonance. All rights reserved.

Sonance, Sonance Symphony, RotoLock and Sonafill are trademarks of Sonance.